

SLOTS 1-12

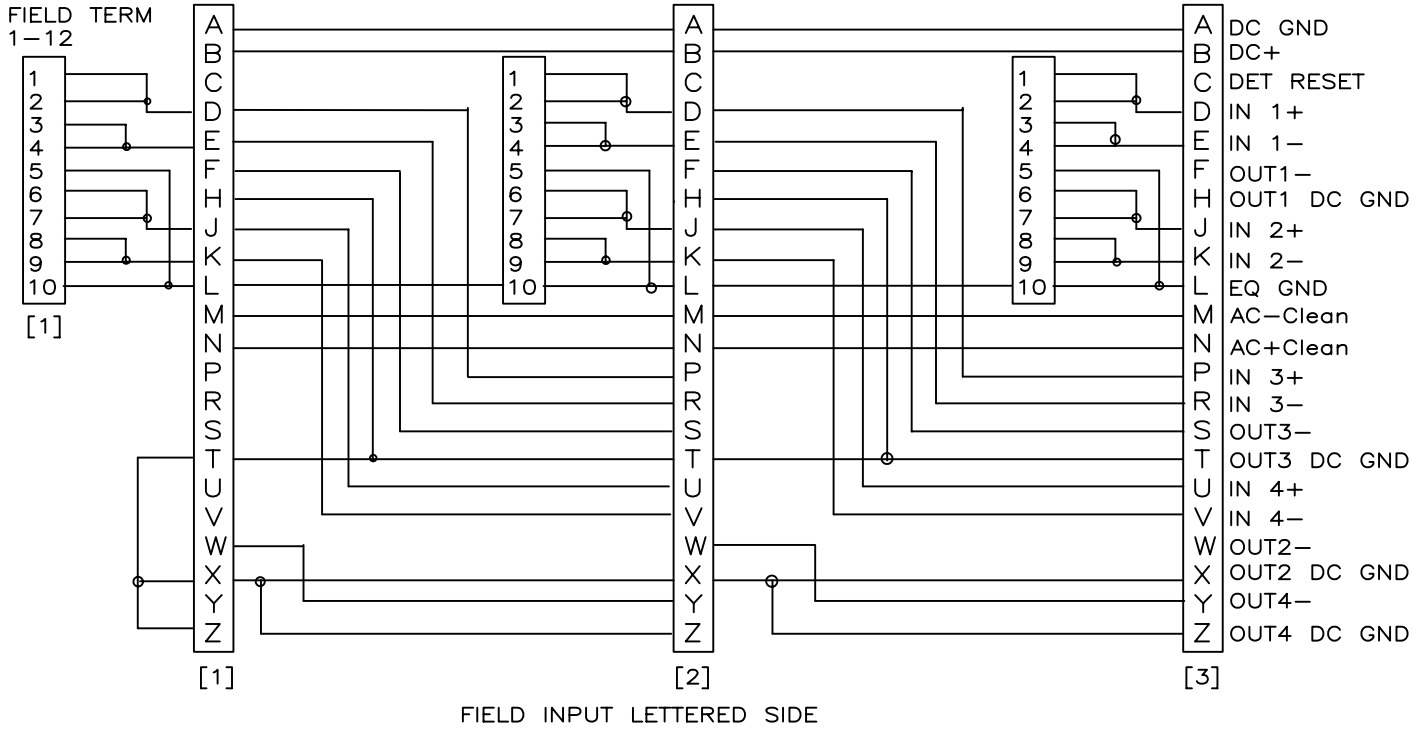

FIELD INPUT LETTERED SIDE

NUMBERED SIDE of Slots 1-12

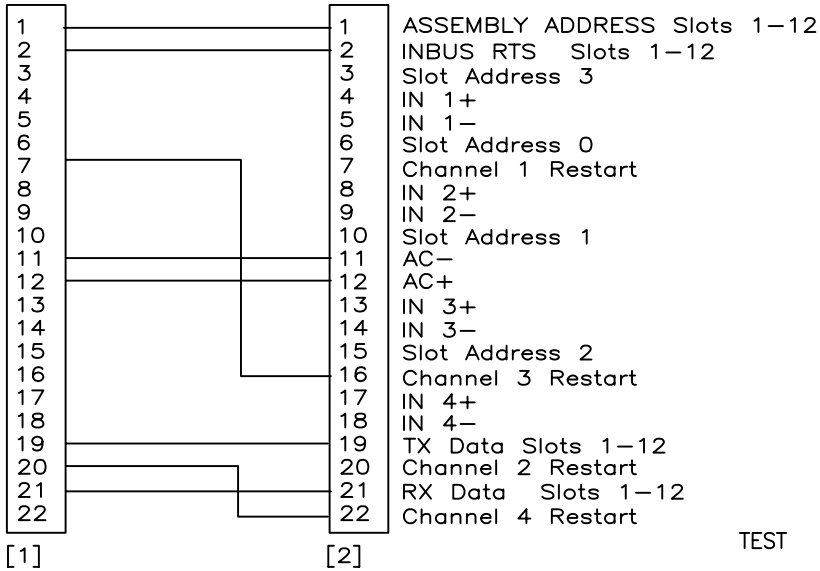

FIELD INPUT CONNECTOR NUMBERED SIDE

TEST Connector

Pin	SIU PIN	SIGNAL	Pin	SIGNAL	SIU PIN
1	A5	IN6	16	B12	IN21
2	B5	IN7	17	A13	IN22
3	A6	IN8	18	B13	IN23
4	B6	IN9	19	A14	IN24
5	A7	IN10	20	B14	IN25
6	B7	IN11	21	A15	IN26
7	A8	IN12	22	B15	IN27
8	B8	IN13	23	A16	IN28
9	A9	IN14	24	B16	IN29
10	B9	IN15	25	B25	OPTO 1
11	A10	IN16	26	A26	OPTO 2
12	B10	IN17	27	B26	OPTO 3
13	A11	IN18	28	A27	OPTO 4
14	B11	IN19	29	B27	COMMON
15	A12	IN20	30	A32	DC Ground
			31	B31	AC LRef

Pins 32 thru 37 not assigned.

TEST

Socket

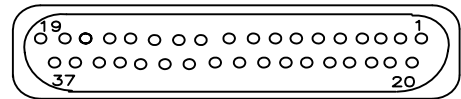

DCP(Plug)
PLUG (Face View)

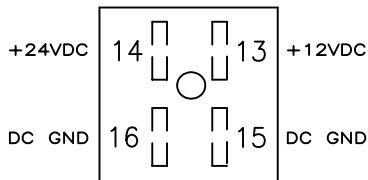

TITLE:

INPUT ASSEMBLY
WIRING DIAGRAMS

Rev Date 9-23-03

MAY 8, 2003

6-5-37