

Advanced Transportation Controller Standards Overview

By: Joint Committee on the Advanced Transportation Controller

PURPOSE AND DESIGN

The Advanced Transportation Controller (ATC) is being developed to provide an open architecture hardware and software platform for a wide variety of ITS applications. In this context the words "open architecture" mean that the system will include both public and private sector developers and have modular software cooperatively running on standardized and shared modular hardware platforms. This will provide cost-effective ITS functionality for a wide variety of applications. To accomplish this goal the system needs to provide the maximum flexibility for many different system configurations and installations.

The general concept and model for the ATC is the PC Computer. However, the ATC will be a field-hardened, general-purpose computer for embedded applications, which with the appropriate software and hardware modules could be asked to perform many different duties.

This overview represents current (Spring 2000) direction for the architecture and implementation for this system.

Listing of Proposed Applications

It is anticipated that ATC will be able (or configurable) to serve at least the following applications:

- Traffic Signal
- Traffic Surveillance
- Transit
- Communications
- Field Masters
- Ramp Meter
- Variable/Dynamic Message Signs
- General ITS beacons
- CCTV Cameras
- Roadway Weather Information Systems
- Weigh in Motion
- Irrigation Control
- Lane Use Signals
- Highway Rail Intersections
- Speed Monitoring
- Incident Management
- Highway Advisory Radio
- Freeway Lane Control
- Electronic Toll Collection
- Automatic Vehicle Identification
- High Occupancy Vehicle Systems
- Violations
- Access Control
- Traveler Information
- Commercial Vehicle Operations

For each application it serves, the controller, cabinet and included subsystems would be selected from a set of standard parts and assemblies. Many of these parts and assemblies will be standardized, and others that may be for a specific application may not.

The committee has focused on the initial traffic control oriented applications: traffic signal control, ramp control; traffic surveillance; lane use signals; field masters; general ITS beacons; lane control; and access control. As a result, the modular structure focuses on providing rack space, power management, and serial buses for the classic traffic control input devices, load switching, and cabinet monitoring to ensure that the ATC cabinet is consistent with past practices. In addition, the serial control and monitoring bus arrangement is modular in nature and will support the development of additional special function oriented assemblies to support some of the ITS functions listed above.

Each application would also employ software specifically written for that application. In some applications the ATC could be running several different software programs in a multi-tasking environment written by several different developers. In fact it is the software program(s) that will differ most between each of the listed applications.

ATC Committees

This is a joint effort sponsored by the Institute of Transportation Engineers (ITE), American Association of State Highway and Transportation Officials (AASHTO), Federal Highway Administration (FHWA) and the National Electrical Manufacturers Association (NEMA). They have assembled a team of experts representing equipment users (public agencies) and industry representatives to develop the design for this next generation of transportation control equipment. This working group has been broken into four groups, a steering committee and three working groups. The working groups are organized around the three main subsystems, Cabinet, Controller Unit, and Applications Programming Interface.

At this point in time, Spring 2000, the work of these committees is not complete and there have been no prototypes constructed and tested to confirm the concepts. However, the ensuing discussion is meant to convey the current direction of the effort. Note that I say "current direction," as until the specifications are complete and field-tested there will most likely be some changes.

The work on the ATC began as an extension of the Type 2070 Controller design. The first product of the committee was to rewrite the Caltrans specifications for the Type 2070 Controller to make it a generic document that any agency could use. For the ATC, different subassemblies and different software packages can be combined to meet a wide variety of applications and configurations. The next effort, which is currently under way, involves the development of an all-new standard that will embody the best aspects of all current controller technologies. The Type 2070 will be one member of this new controller family.

General System Architecture

In the ATC System there are two major assemblies, the cabinet and the controller. Within each major assembly there are subassemblies, or in the case of the controller application software, packages, that add to the system functionality. The system is much like the menu at an ala carte restaurant where you can pick things from a number of menu areas to suit your taste (sort of a mix and match approach.)

CABINETS

The cabinet functions as much more than simply housing a collection of electronic boxes. The cabinet provides the communications paths between the various sub systems as well as a system to monitor their operation. Further, the cabinet provides power supplies suitable for the various electronic subassemblies mounted throughout the cabinet. In general, the ATC cabinet is an extension of the original cabinet used for the Model 170 controller in that it is based upon the EIA/TIA standard 19-inch equipment rack. In this rack the subsystems that comprise the field controller assembly are mounted. The controller and other subassemblies are also similar in concept to the Model 170 system in that they are essentially interchangeable circuit cards or device cages. However, this will not preclude other cabinet constructs such as are proposed for the Cabinet Housing 4 or for retrofits to existing NEMA TS1 and TS2 type cabinets or other more specialized cabinets, as long as the architecture of the serial buses is maintained.

Each of the subassemblies is connected to the controller using a serial bus similar to that used in the NEMA TS2 specification. Using a serial interconnection between subassemblies allows for massive system expansion. The system will support up to 24 load switches in 6 switch increments and 96 detector channels in 24 channel increments. As will be shown later, this serial bus can also be extended using inexpensive

fiber optic transceivers such that multiple remote switching/data collection cabinets can be supported from a single controller.

Cabinet Subsystems

The major subsystems that may be installed in a cabinet housing are:

- Controller
- Input Assembly(s)
- Output Assembly(s)
- Power Distribution Assembly
- Fiber Optic Splice Tray
- Modular Serial and Power Bus
- Modular Power Assembly
- Cabinet Monitoring System

The cabinet is constructed in a modular manner with power distribution and serial connectors conveniently located throughout the cabinet to facilitate a wide variety of configurations and future expansion. Each of these subassemblies is discussed below. A separate section describes the controller.

Input Assembly

The input assembly provides services for the typical inductive loop detectors currently in use as well as other more advanced systems that might provide the controller with serial data instead of the typical contact closure. Each assembly will accommodate one Serial Interface Unit (SIU) to communicate with the controller. The rack has space for 12 two-channel detector units. The system can address (i.e the Serial Bus addressing structure supports) up to four of these assemblies.

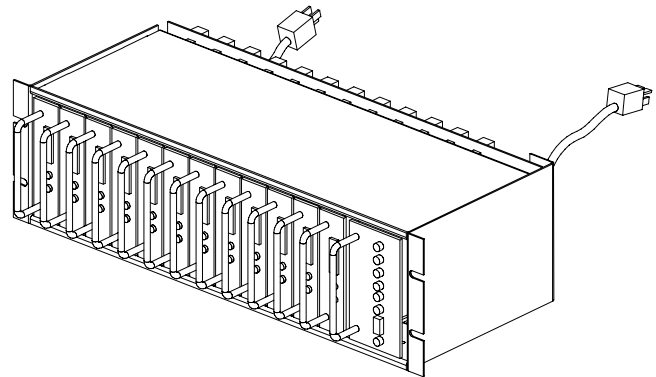

The detectors in the assembly can communicate to the controller in the form of either a contact closure or use of serial data strings. This will allow for the use of “smart” detectors that can pass additional information such as vehicle classification, Automatic Vehicle Identification/Location information, speed information directly to the controller unit, or video image-based detection units. Each slot provides general purpose power and input/output signals and a serial interface.

The input “slots” can also accommodate the standard collection of Model 170 type cards, including preemption devices, and isolation modules, using the contact closure interface.

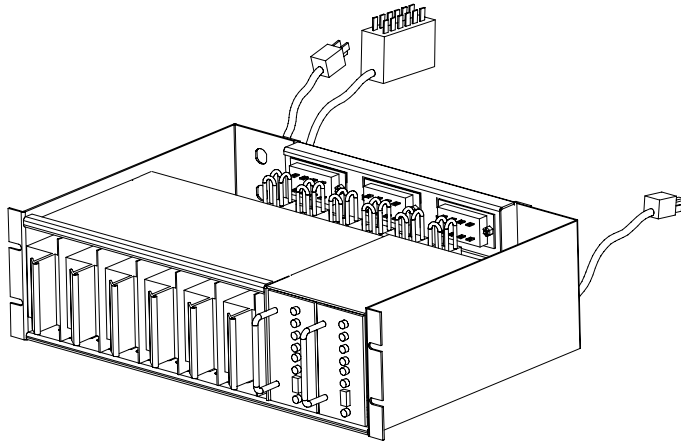

Output Assembly

The output assembly handles the switching of 120-volt power to the signal heads. Each assembly can accommodate six load switches. It also has a SIU and an Auxiliary Monitor Unit (AMU). The AMU will be described in detail in a following section. The output assembly includes provisions for managing cabinet flash with Flash Transfer Relays and flash configuration jumpers.

To support the AMU function of current monitoring, the output assembly includes current monitoring transformers for each load switch.

These current monitor transformers

will be able to detect a “no-load” condition on a signal without having to wait for the signal to cycle.

The system can address (i.e. the Serial Bus addressing structure supports) up to four of these assemblies for a total of 24 load switches or physical channels plus eight virtual channels for a total of 32 logical channels.

The field wires can also be connected to the back of this unit using plug-in type connectors. The field wires would be terminated in these connectors, which would then be plugged into the back of the Assembly. This will facilitate the change out of the assembly or the whole controller and housing assembly.

Power Distribution Assembly (PDA)

The PDA provides clean protected power to the various devices and subassemblies within the cabinet assembly. This assembly also houses the flasher control relays, signal power contactor, and the Cabinet Monitor Unit (CMU).

There are two different units: PDA #5 one for more general use with two flashers, and PDA # 6, intended for use in ramp meter or similar installations where no flasher would be needed.

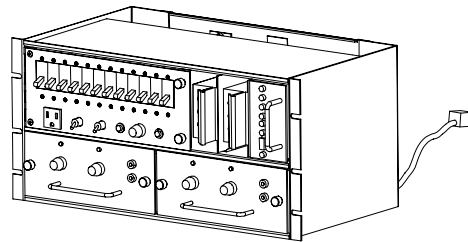

The PDA also houses two low voltage DC power supplies. One provides power to 24-volt devices, the other to 12-volt devices. Each of these power supplies is packaged as a slide-out subassembly.

Fiber Optic Splice Tray

The fiber optic splice tray provides a safe protected environment for splicing the incoming fiber cable to pre-terminated pigtails. The pre-terminated pigtails are then mounted on a bulkhead to which jumper cables that are connected to the devices are fastened.

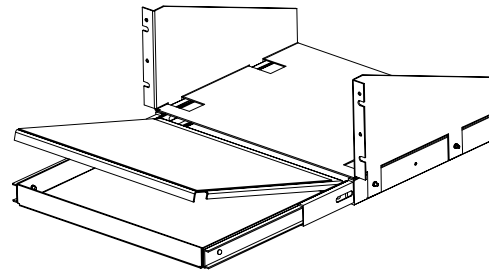

Modular Bus

The modular buses are assemblies that are mounted on the rack rails in the back of the cabinet to provide a pluggable interconnection of the Assembly units to the controller unit and power. These assemblies control and protect the wiring between these key subsystems, provides additional shielding from electromagnetic interference. Their biggest benefit is to simplify cabinet assembly.

The cabinet may have any combination of these bus units depending upon the particular application. For example, a cabinet designed as a communications hub may only have a Modular Power Assembly unit. Cabinet Housing 4 may not have any of them and those installed in Cabinet Housing 2 would have shorter versions of them.

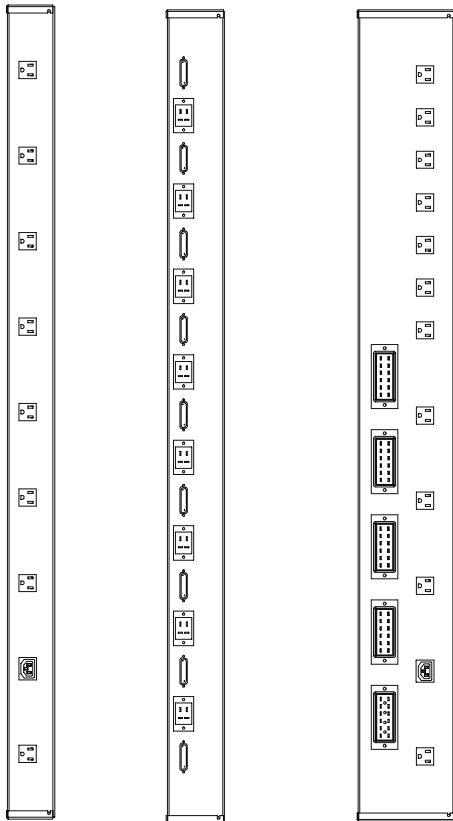

Modular Power Assembly **Modular Bus (DC Power Serial Comm)** **Modular Bus (AC Power Equipment Power)**

Modular Power Assembly

The modular power assembly attaches to the rear rack rails opposite of the modular bus assembly. This assembly is wired to provide both 120-volt AC to the controller and to the output assemblies. There are two versions of this assembly one that contains the sockets for output assembly connection and standard three prong equipment plugs and one with only the standard three prong equipment plugs. The second assembly is primarily meant for those cabinets without output assemblies or use in the Cabinet Housing 3.

DC Power and Serial Communications

This modular bus assembly provides either 12 or 24 volt DC power to cabinet devices, primarily the input assemblies. It also houses the wiring for the serial buses 1 and 2 communications between the SIUs, CMUs, AMUs and the ATC controller.

AC Power and Equipment Power Bus

This bus provides power and signaling for the output assemblies. It contains links to the Flash Transfer Relays and provides power to the load switches. It also has 120 volt filtered power outlets for cabinet equipment.

Cabinet Monitoring System

The cabinet monitoring system provides a fail-safe mechanism for the entire collection of subassemblies. The system for the ATC is a departure from its predecessors in that it has been split into sub components, the Cabinet Monitor Unit (CMU) and the Auxiliary Monitor Unit (AMU). The following diagram illustrates the architecture.

The real power of this architecture is that it allows the customer a much greater degree of flexibility in cabinet configurations than previously possible. This diagram shows the control system for a single intersection. The use of serial communications to the CMU is a very powerful concept. A later section shows a series of examples where a single controller can operate multiple intersections. Serial communications to multiple CMUs will allow response to a conflict at a single intersection and not impact other intersections/ramps/etc. operated by the same controller. Therefore one intersection could go to flash independently of the others provided that each cabinet (or each independent output assembly) has a PDA into which is installed a CMU.

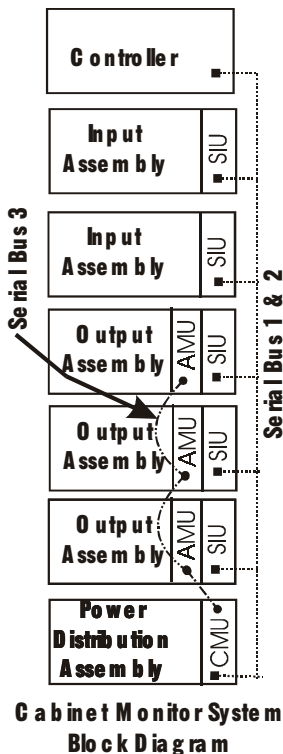

Cabinet Monitor Unit (CMU)

The CMU is housed in the PDA. There should only be one of these installed in each cabinet or each grouping of output assemblies. It is the main processor unit of the cabinet monitoring system. It monitors main cabinet functions such as the condition of cabinet power, door status, and status of the flasher. It communicates with the AMUs located in the output assemblies and compares requested actions (from the controller) with the actual cabinet operation (load switch outputs) to detect errors, conflicts, and other anomalies. It can then direct the cabinet to a flashing or fail-safe condition.

The exception here is the Cabinet Housing 3, which could contain two separate groupings of input, output and power distribution assemblies for two separate intersections all controlled by a single controller. See the examples at the end of the document for more details on how this might be configured.

The configuration and operational characteristics of the CMU will be determined by software. This programming may be customized to customer needs and desires. There will also be a specific reporting format and order to address the minimum mandatory functionality of this unit. The minimum functionality will be at least that provided by the NEMA TS2 Malfunction Monitoring Unit.

To allow full programmability of the CMU, without a massive number of physical jumpers, the Model 210 and NEMA diode based conflict programming board will be replaced by a Data Key used on the CMU. This Data Key will contain all information to configure the monitoring system.

The CMU would carry an address so that multiple CMUs could be used to provide multiple intersection control assemblies controlled by a single controller. Maximum number of CMUs has yet to be determined. See the examples at the end of the document to see how this arrangement might work.

Auxiliary Monitor Unit (AMU)

The AMU is housed in each output assembly. This unit does the basic monitoring of the output of the load switches and reports their statuses to the CMU. It is essentially a device that monitors the output voltage and current of each circuit and the current of each load switch. This module communicates to the CMU via Serial Bus 3. Having this unit as a separate module from the CMU allows greater modularity of the cabinet. The cabinet can then contain a grouping of between one and four output assemblies. However, the grouping of output assemblies and associated CMU connected via a single Serial Bus 3 would remain as an associated grouping and not be split to different cabinets.

Data Key

This key is essentially a non-volatile computer memory device. It is housed in the Cabinet Monitor Unit. It contains all the specific information to define unit operations and malfunctions. In general it replaces the Model 210 and NEMA Conflict Monitor Programming Card plus information previously programmed into those units except that the data key will not contain the controller operating and application software. Startup processes within the cabinet will allow the CMU and the controller to verify a compatible configuration before starting normal operation.



Cabinet Communications Systems

The controller communicates with the various cabinet subassemblies via a serial bus arrangement. There are actually three separate serial buses employed. These buses are similar to those used in the NEMA TS2 specification and communicate using a Synchronous Data Link Control (SDLC) protocol. The Cabinet Block Diagram provided above illustrates how this system is configured. The electrical characteristics of this communications circuit are defined by EIA 485 specifications.

Serial Interface Unit (SIU)

The SIU functions as the cabinet communications and control unit. The SIU communicates with the ATC Controller Unit through Serial Bus 1 and Serial Bus 2 via the Modular Bus Assembly. In the case where the input and/or output assembly is mounted remotely, communications would be over a data grade interconnect cable. This cable will most likely be a fiber optic cable because of its high noise immunity, reliability, and the ability to provide the bandwidth needed for this important communications link.

A SIU is needed for each input assembly and each output assembly connected to the ATC Controller Unit.

Serial Bus 1

This bus communicates real time information required to operate the system. It handles the highest priority, time sensitive data exchange between the SIUs in the input and output assemblies, controller unit and the CMU. An example would be the commands to the load switches to change signal color or data from detection inputs.

Serial Bus 2

This bus communicates less time critical information between the SIUs in the input and output assemblies, the controller unit. An example would be servicing requests for general program information as might be requested from a central computer system.

Serial Bus 3

This bus is dedicated to communications between the AMUs and the CMU. It is used to allow the CMU to monitor the various voltages, operating conditions, and currents in the output assemblies to determine actual load switch conditions.

Standard Cabinet Assemblies

There are four different cabinet assemblies, which consist of a specific collection of the subassemblies described above. Each of these assemblies is installed in a cabinet that is designed for a particular group of applications and is sized to hold the equipment required. In most cases the cabinets have doors both on the front and the back. The exception is Cabinet Housing 4, which is meant to be mounted on the side of a pole and has only a single door. The equipment is mounted on a standard EIA 19" rack that is fitted inside each cabinet.

Each cabinet includes at least the following common features:

- Enclosure
- Doors
- Latches/Locks
- Hinges and Door Catches
- Gasketing
- Police Panel
- Ventilation and Air Filtration
- Assembly Supports and Mounting

Cabinet Housing 1

This Cabinet Housing is very similar to the Type 332 series of cabinet used for the Model 170 Controller system. It is a single rack cabinet with sufficient capacity to operate a full eight-phase traffic signal. Dimensions are width 615.95mm (24.25”), depth 768.35mm (30.25”), and height 1696.21mm (66.78”).

Cabinet Housing 2

This shorter version of Cabinet Housing 1 is very similar to the Type 336 series of cabinet used for the Model 170 Controller system and is meant for applications that require less space for inputs and outputs. This cabinet might be found at small two through eight-phase traffic signals, ramp meters, data stations and similar less space demanding applications. Dimensions are width 615.95mm (24.25”), depth 514.35mm (20.25”), and height 1174.75mm (46.25”).

Cabinet Housing 3

This is a large two rack, four door cabinet similar in size to the NEMA P cabinet. It is meant for installations requiring a lot of equipment. An example application may be a traffic signal controller with a communications hub or a ramp meter, or perhaps additional input/output assemblies. Dimensions are width 1130.30mm (44.5”), depth 660.4mm (26”), height 1686.05mm (66.375”).

Cabinet Housing 4

This is small single door cabinet meant for traffic signals installed in central business district applications. It contains enough equipment to operate a simple three-phase traffic signal with a minimal amount of detection. Width 559mm (22.00”), depth 428.27mm (17.5”), height 850.9mm, (33.50”).

CONTROLLERS

The ATC Controller Unit is designed as a modular unit to facilitate customization for the particular application and for future expansion and updates, yet to retain sufficient standardization to allow interchangeability of key components. It also allows some latitude for manufactures to customize the packaging. At this writing, the CPU, or Engine Board as we are calling it, will be modular and interchangeable between manufactures. Other components of the controller unit will not be required to be interchangeable between manufactures, thus allowing maximum packaging flexibility which will allow the most cost effective design implementations where needed, as well as allowing for very small designs where needed for size restricted applications. The standard will not preclude other packaging implementations, which may be fully modular by function. Thus the standard will allow for the very cost sensitive design implementations, as well as highly modular and expansible design implementations. Key features and modules of the controller unit are as follows.

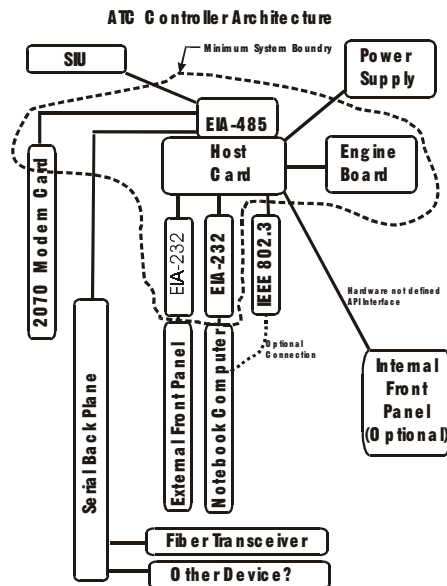

Controller Housing

The controller housing could take many forms depending on the manufacturer and application. For example, an EIA 19" rack mounted form would be needed for installation into Cabinet Housings 1, 2 and 3. The Type 2070 controller generally fits this concept.

A shelf-mounted unit may be needed for Cabinet Housing 4. However, it is also possible that a shelf-mounted unit could be installed in any of the housings.

It is also possible that the ATC could be configured such that it could be retrofitted to existing 332 and NEMA TS1 and TS2 cabinets. It also will not limit its installation into any other cabinet form that a customer might desire. For instance, consider the custom cabinets typically used in Roadway Weather Information Systems or Electronic Toll Collection systems.

This would also allow the possibility that there is no physical housing for the controller. It could be that the engine board/host board assembly could be plugged directly into the infrastructure of a Cabinet Housing 4 to minimize the size of the whole unit.

For example the range of controller housings that might be employed could be from a small one sufficient to house a single board implementation with no front panel or be large enough to house a large number of slide in cards, a back plane and full function front panel.

CPU

The CPU comprised of Engine Board. The Engine mounted to the as a daughter proposal is that would be used together. The two boards defined to

Board could be mounted and operated on any Host Board.

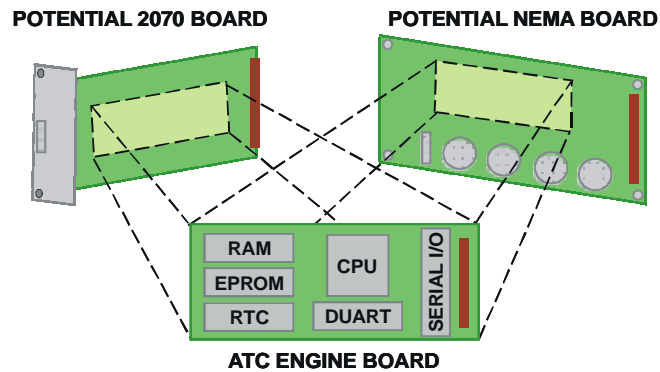

Assembly

Assembly would be two main parts, the and the Host Board. Board would be Host Board essentially board. The current two 50 Pin connectors to connect these boards interface between the would be strictly ensure that any Engine

Engine Board

The Engine Board is the heart of the controller unit. The processor, memory devices, all processor housekeeping circuits, and serial interface devices, including Universal Asynchronous Receiver Transmitter (UART), Universal Synchronous Asynchronous Receiver Transmitter (USART), will be located on the engine board. The interface between the engine board and the host board will be at logic levels. The form factor of this engine board will allow it to fit on a host board capable of being installed in the existing Type 2070 controller unit, but won't preclude it from being installed on any other form of host card as may be appropriate for any application.

This engine board will also accommodate future updates to the CPU (Central Processing Unit or microprocessor), Operating System (OS) and memory requirements of the controller. It will also allow for some customization of the CPU requirements to meet the application. For example, a controller unit installed as a simple data collection device will require less processing power than one installed to operate a complex traffic signal.

Updating or expanding system capability may be as simple as changing the engine board. The Engine Boards would be interchangeable between vendors.

The specifications for the engine board will state a minimum real-time processing capability. A future task of this committee will be to develop a software suite to further define, test, and measure whether a proposed engine board meets or exceeds this minimum.

Host Board

The Host Board will “hold” the Engine Board. All EIA/TIA-232, 485 or Ethernet physical layer interface circuits will reside on this “host” interface module. This module will in turn connect to other controller devices via a backplane assembly or ribbon cables.

A standardized connector will be used to connect to the engine board.

In general there will be no limitations, other than the standard interface to the engine board and the Type 2070 modem cards, on what may or may not be part of this host board. For the most cost sensitive installations, the host board could include the EIA 485 chip set to communicate to the SIUs, front panel, and other communications devices and the internal power supply.

This host board may also have the capability to interface with a bus type back plane to allow greater system expansion and capability. In that case the hardware enclosure would also have to have the facilities for the back plane and card rack for these devices.

A non-volatile memory device such as the Data Key used in the CMU or the one used in the Type 2070 controller most likely will be installed on this board. It will contain key program variables and backup timings for intersection operation.

Communications Modules

These modules will communicate with devices external to the controller unit such as the SIUs, the controller front panel and modems. These modules may be constrained to a common form factor. For external communications devices such as modems, this form factor will be the same as that of the existing Type 2070 modules so that the existing inventory of communications devices can be used.

For many applications, a communications module may not be needed. In these cases the basic communications chores could be handled by the host card rather than having to install a communications module. In concept it is similar to many present day notebook computers with a built-in V.90 modem, which can be supplemented or replaced by a PCMCIA based plug-in communications device.

Power Supply

Each controller unit would contain a power supply module to convert 120-volt power to voltages required to operate the electronics inside the controller unit. This power supply would meet certain basic electrical characteristics but would be custom designed to fit with a specific manufacturer’s unit.

This, however, does not preclude a manufacturer or an agency from requiring a specific power supply form factor so that it is consistent across a wide range of packages that may be employed by that agency.

Front Panel

The Controller Front Panel will contain a keyboard and display that would comprise the user field interface. With this new controller unit the Front Panel will be optional. Communications to the controller processor may be over one of the serial ports.

The front panel can also be used as a portable input device rather than or in addition to a notebook PC. This will offer a low cost alternative and will provide a minimum functionality for those agencies that have trouble purchasing and supporting notebook PCs.

The hardware for the connection of the front panel to the host will not be defined. However, an API will be defined for this interface, such that the application program will have a uniform and consistent method of communicating to it.

Proposals at this time will be for the front panel to have a keyboard and a graphics enabled display. However, this could be modified depending upon specific application and user requirements.

SOFTWARE

The ATC is designed as an open architecture hardware platform on which a separate software program will operate. There are really three distinct parts to the software that will be installed on the hardware platform, the Application, the Applications Programming Interface (API), and the Operating System (OS). Breaking the system into these three parts will allow a huge amount of freedom to specify and implement any of them independently of the others. For example, if a hot new CPU and OS hit the market these can be specified in the system with little or no impact to the application or the hardware package. The key to this freedom is the API, which is a software buffer between the application and CPU/OS combination.

Multi-Tasking

The other key part of the software programming of the system is that the system must be able to run multiple applications simultaneously in real time.

Applications

The hardware platform is designed to support a wide variety of applications as listed in the beginning of this document. Programming of the applications will most likely be done using the “C” family of programming languages although other programming languages could be used. The hardware platform and programming shall be designed to support multiple applications running simultaneously on the same unit. It is not required that the applications be supplied by the same supplier and could be for separate applications.

Applications Programming Interface (API)

The Applications Programming Interface is a key component to the system. It serves as an interface between the Application Program, the Operating System, and the CPU/hardware. The API currently only supports the “C” family of programming languages for the Motorola 68360 microprocessor. Ultimately by utilizing the API, the same application can be run on different CPUs and/or operating systems. For example one controller in the system might utilize a CPU from the Motorola family and another one a CPU from Intel. Each could use a different OS without requiring completely different application programs. Also as new CPUs come to market and older ones go out of production, the application will not have to be rewritten. Since hardware platforms may differ from supplier to supplier, the API will generally be provided by the hardware supplier, thus giving a consistent interface to the application programs.

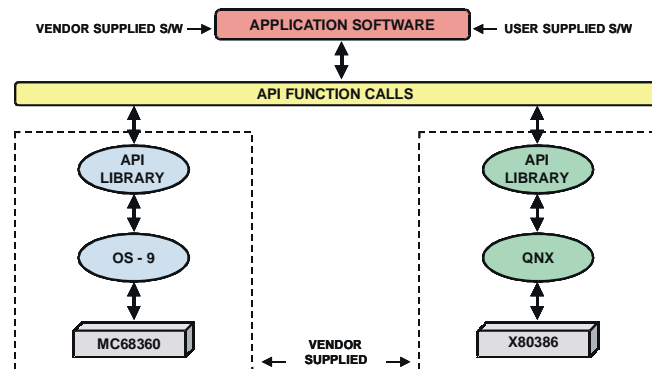

Operating Systems

The operating systems used on the ATC are embedded *real-time* operating systems. Currently the Type 2070 controller specifies a particular version of the OS-9 operating system operating on a Motorola 68000 series CPU. However, the future ATC will not require a specific operating system. Since the API isolates the application from the hardware, any *real-time* operating system could be used. Examples of other operating systems that are currently being discussed include OS-9 (for other CPU platforms) Vx Works, QNX for Intel based systems, or some form of proprietary operating system. Given that the average production life of many CPUs is often measured in months, the ATC needs to be configured for future CPU upgrades without discarding the whole unit.

The message here is that the ATC will only depend upon having a real time operating. Whether it uses a complex or reduced instruction set or is a version of UNIX will not impact the application.

EXAMPLES

In order to better convey the power and modularity of the system, five examples are provided. The first two are simple and will be installed in many places, and the last is a complex combination of all the elements of the ATC.

Example 1. The ATC for a Traffic Signal Installation

This assembly is projected to account for the majority of ATC installations. It represents an installation similar to the existing Model 170 and NEMA TS2 installations controlling the typical eight-phase traffic signal. The system provides additional flexibility so that more complex intersections with significantly greater than eight phases can be accommodated.

For a traffic signal application, the assembly would need the following equipment:

- ATC Controller
- Output Assemblies (4 Maximum)
 - SIU
 - AMU
 - Flash Transfer Relays
 - Load Switches
- Input Assemblies (4 maximum)
 - Detector Devices (12 Maximum per Assembly)
 - SIU
- Power Distribution Assembly #5
 - Flashers (2)
 - CMU
 - 12 Volt Power Supply
 - 24 Volt Power Supply
 - Power Distribution Circuit Breakers
 - Power Filtration/Surge Protection
- Cabinet Housing 1

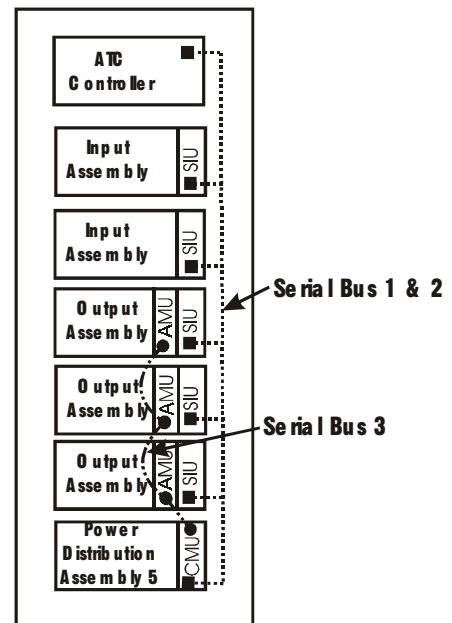

Example 1
Traffic Signal Controller
Cabinet Housing 1
 (shown with 18 load switches)

Example 2. The ATC for a CBD area Traffic Signal

The ATC for the CBD installation would provide only minimal services and is intended for a maximum three vehicle phases and two pedestrian phases, plus there is an additional load switch that can be used to control an extinguishable message sign such as one to control a time-of-day turn restriction.

- ATC Controller
- Output Assemblies (1 Maximum)
 - SIU
 - AMU
 - Flash Transfer Relays
 - Load Switches
- Input Assemblies (1 maximum)
 - Detector Devices (12 Maximum)
 - SIU
- Power Distribution Assembly #5
 - Flashers (2)
 - CMU
 - 12 Volt Power Supply
 - 24 Volt Power Supply
 - Power Distribution Circuit Breakers
 - Power Filtration/Surge Protection
- Cabinet Housing 4

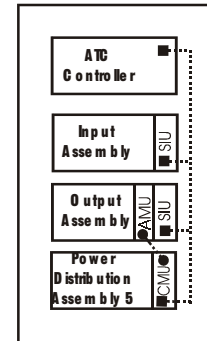

Example 2
Traffic Signal Controller
In Cabinet Housing 4
(shown with 6 load switches)

Example 3. The ATC for a Ramp Meter

The ramp meter installation takes advantage of Power Distribution Assembly #6. The CMU would be needed to monitor the output assembly, the voltages in the cabinet and the condition of the controller itself.

- ATC Controller
- Input Assemblies (1 maximum)
 - Detector Devices (12 Maximum)
 - SIU
- Output Assemblies (1 maximum)
 - SIU
 - AMU
 - Flash Transfer Relays
 - Load Switches
- Power Distribution Assembly #6
 - CMU
 - 12 Volt Power Supply
 - 24 Volt Power Supply
 - Power Distribution Circuit Breakers
 - Power Filtration/Surge Protection
- Cabinet Housing 1, 2 or 4 (or as an additional assembly in a Cabinet Housing 3)

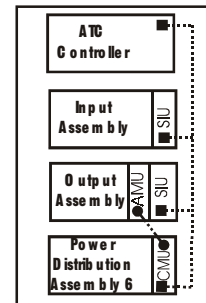

Example 3
Ramp Meter
In Cabinet Housing 2

Example 4. The ATC for a Data Station

This example is very similar to the ramp meter, except that there would be no flashers or load switches. The CMU would be needed to monitor the voltages in the cabinet as well as the condition of the controller itself.

- ATC Controller
- Input Assemblies (1 maximum)
 - Detector Devices (12 Maximum)
 - SIU
- Power Distribution Assembly #6
 - CMU (to monitor system power etc.)
 - 12 Volt Power Supply (optional)
 - 24 Volt Power Supply
 - Power Distribution Circuit Breakers
 - Power Filtration/Surge Protection
- Cabinet Housing 1, 2 or 4 (or as an additional assembly in a Housing 3)

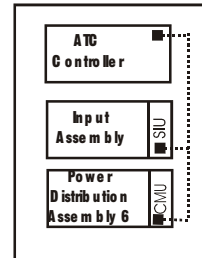

Example 4
Data Station
in Cabinet Housing 2

Cabinet

Example 5. Traffic Signal Controller with Communications Hub

In this example a communications hub is jointly housed with a traffic signal controller in a Cabinet Housing 3. This could very easily be a traffic signal controller with a Ramp Meter.

Another application might be a single cabinet controlling two intersections such as at a tight diamond interchange or a complex offset intersection. In these applications there would be a single ATC Controller driving two sets of input and output assemblies.

In the example shown, the communications hub is powered by a separate PDA. This assembly is monitored by a separate CMU, which monitors the power and reports that status back to a central location. This CMU is directly connected to a separate communications link to a central monitoring station. Given the flexibility possible with the CMU it could be programmed and wired to report other information from the communications hub equipment.

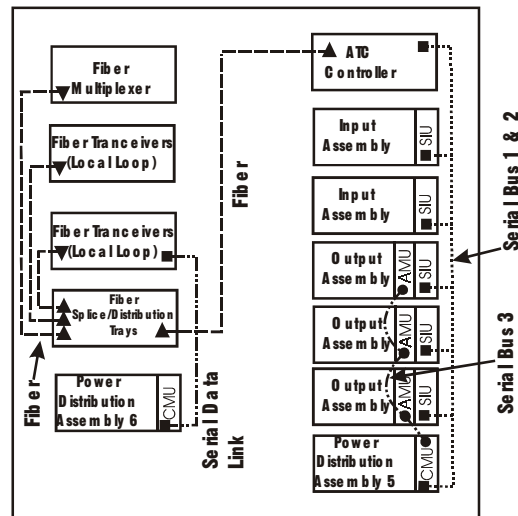

Example 5
Traffic Signal Controller
Communications Hub
Cabinet Housing 3
(shown with 18 load switches)

Putting It All Together

The following is an example of the potential power of the system. The diagram shows a single controller running a complex installation that may exist at a diamond interchange that has an adjacent frontage road. You may not want to run this in many locations with a single controller, but for some of the more complex situations, the power is there to efficiently accommodate them.

The modularity of the Cabinet and Auxiliary Monitoring units will allow each location to go to flash independent of the others. The strength of the application programs would allow for the adjacent intersections to automatically change to better service traffic in the event of this failure.

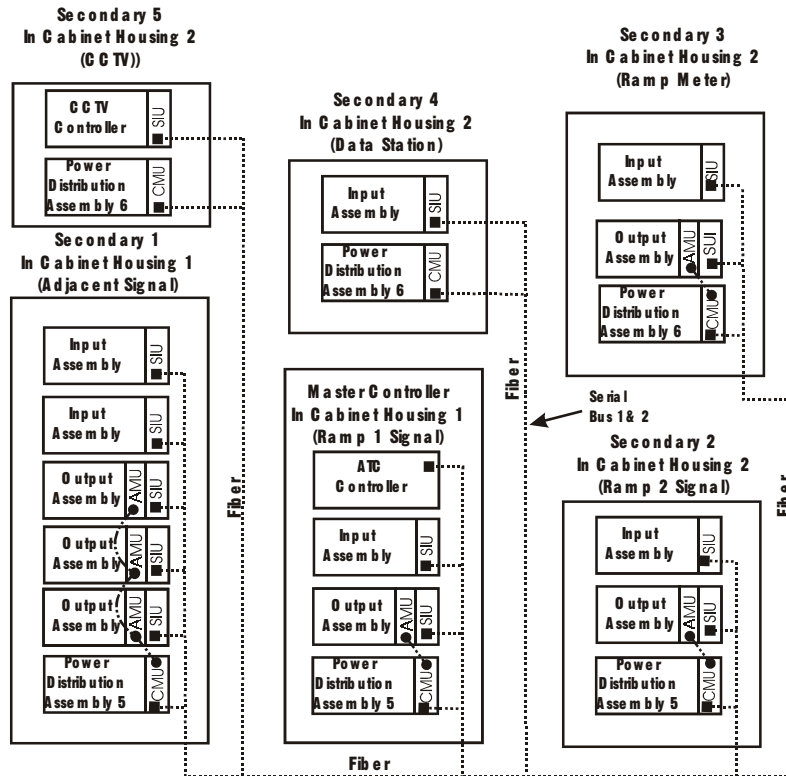

CONCLUSION

The ATC is an open architecture hardware and software platform for the next century. The design takes advantage of a wide field of experience with previous generations of transportation system control equipment. It will also allow easy integration of the many new technology devices that may become available in the future.

A more powerful and adaptable Central Processing System will also greatly facilitate the implementation of the new NTCIP protocols and provide the processing power needed for more advanced adaptive control strategies. It will also provide a platform for allowing the traffic signal controllers to capitalize on the advances in computer technology with minimal impact on the software investment.

ACKNOWLEDGEMENTS

The Advanced Transportation Controller Steering Committee acknowledges the work of Paul R. Olson, P.E., FHWA Western Resource Center, in leading the effort to author this article and the leadership of Raj Ghamen, FHWA Research and Development, for his championing the ATC initiative from its initial concept through its formative stages.

CONTENTS

Purpose and Design	1
Listing of Proposed Applications	1
ATC Committees	2
General System Architecture	2
Cabinets	2
Cabinet Subsystems	3
Input Assembly	3
Output Assembly	4
Power Distribution Assembly (PDA)	4
Fiber Optic Splice Tray	5
Modular Bus	5
Modular Power Assembly	5
DC Power and Serial Communications	5
AC Power and Equipment Power Bus	5
Cabinet Monitoring System	6
Cabinet Monitor Unit (CMU)	6
Auxiliary Monitor Unit (AMU)	6
Data Key	7
Cabinet Communications Systems	7
Serial Interface Unit (SIU)	7
Serial Bus 1	7
Serial Bus 2	7
Serial Bus 3	7
Standard Cabinet Assemblies	7
Cabinet Housing 1	8
Cabinet Housing 2	8
Cabinet Housing 3	8
Cabinet Housing 4	8
Controllers	8
Controller Housing	9
CPU Assembly	9
Engine Board	9
Host Board	10
Communications Modules	10
Power Supply	10
Front Panel	10
Software	11
Multi-Tasking	11
Applications	11
Applications Programming Interface (API)	11
Operating Systems	12
Examples	12
Example 1. The ATC for a Traffic Signal Installation	12
Example 2. The ATC for a CBD area Traffic Signal	13
Example 3. The ATC for a Ramp Meter	13
Example 4. The ATC for a Data Station	14
Example 5. Traffic Signal Controller with Communications Hub	14
Putting It All Together	15
Conclusion	15