

1 **2 INTRODUCTION**

2 **2.1 Scope**

3 With the growth of Intelligent Transportation Systems, transportation management
4 increasingly relies on electronically controlled devices deployed in the field and the
5 controllers that coordinate and relay data from those devices. This standard describes a
6 family of advanced, ruggedized, field communications and process controllers that are
7 configurable for a variety of traffic management applications. Typically, they provide
8 communication, control, and data gathering from and to
9

- 10 • Central control computers when appropriate
11 • Other controllers when appropriately configured
12 • Control units for devices deployed in the field, typically in the vicinity of and linked
13 to the controller.

14
15 Essentially, an ATC is a special function computer that must be able to operate remotely
16 in a largely unattended mode in the harsh environment of field deployments throughout
17 the United States.

18
19 The goal of this standard is to provide an open architecture design for the next
20 generation of transportation controller applications. These controllers are modular in
21 design and intended to be compatible with or inclusive of existing (present day) traffic
22 controller capabilities. First, the design specified in this standard is based on the
23 concentration of computing power in a single component (the Engine Board) that is
24 interchangeable with Engine Boards designed by other manufacturers. Second, the
25 standard provides for required and optional features, all of which are based on open
26 standard, common protocol communication standards. Third, the standard is responsive
27 to the functional requirements identified in Section 4 below.
28

29 ***Guidance: The NEMA/AASHTO/ITE API shall run on controllers designed to this***
30 ***ATC standard. (Authorized Engineering Information).***

31
32 Figure 2-1 provides details of the component parts of the ATC and their connections.

Advanced Transportation Controller (ATC) Standard

INTRODUCTION

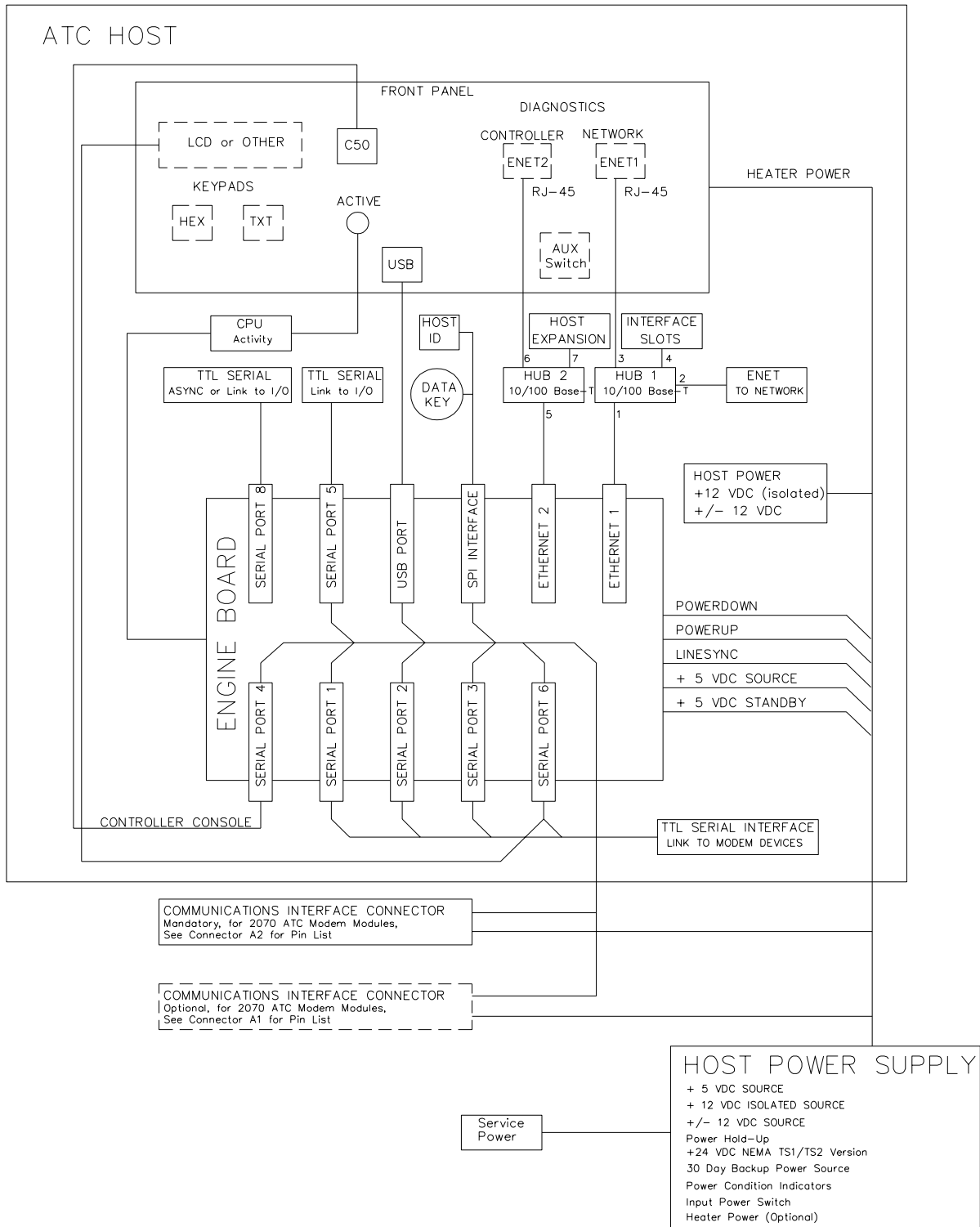

1
2

Figure 2-1: Component Parts of the ATC Controller and their Connections.

1 **2.2 Key Elements of the ATC Controller Standard**

2 **2.2.1 Form/Fit/Function**

3
4 The ATC provides for easy hardware upgrades to adapt to newer processors, operating
5 systems, and increased memory size and speed. It does this by requiring that the
6 Engine Board (CPU module) conform to a designated specific physical form and pin-out
7 interface. Pins designated as “Reserved” allow for future enhancements to the Engine
8 Board and are not to be used for any purpose. They shall be no-connects on both
9 Engine Board and Host modules.

10
11 While the ATC packaging is ultimately left open to allow manufacturers to be responsive
12 to special needs, this standard describes packaging and interfaces that allow the ATC
13 Controller to be deployed in industry standard cabinet configurations.

14
15 The overall ATC physical design allows for either rack mount or shelf mount cabinet
16 configurations.

- 17
18 • Controller units shall be capable of being mounted in rack cabinet including, but
19 not limited to, cabinets adhering to the new ITS Cabinet standard and the Model
20 332 cabinet specifications.
- 21 • If used in standard NEMA TS1 or TS2 cabinet, the controller unit shall be shelf-
22 mounted.

23
24 Note that many of the design choices in this standard reflect the basic requirement that
25 the ATC provide backward interface compatibility with existing NEMA TS1, TS2,
26 Caltrans Model 170, NYDOT Model 179, and ATC 2070 controllers and NEMA Model
27 332 and ITS cabinets.

28 **2.2.2 Engine Board**

29
30 All computational functions are concentrated on an Engine Board within the ATC that
31 meets designated minimum requirements on:

- 32 • CPU and RAM memory
- 33 • FLASH memory storage
- 34 • Serial ports
- 35 • Ethernet interface
- 36 • Standardized (form, fit and function) pin out interface
- 37 • Clock/calendar maintenance
- 38 • Board Support Package
- 39

2.2.3 Communications and User Interfaces

This standard requires at least one and at most two Communications Interface slots be provided by an ATC. These slots are further described in Section 6 of this standard and must adhere to the form, fit and electrical interface specifications of the communications interface slots provided by the ATC 2070. This standard does not require that either of these slots be populated.

Section 7 of this standard defines the required front panel interfaces of the ATC and defines the allowable optional interfaces. In this standard, alternative user interfaces may be included provided that the minimal interface is also provided.

2.2.4 Parallel and Serial I/O

The ATC provides industry-standard communication interfaces for asynchronous and synchronous serial communications.

This standard also requires a minimum of one synchronous serial port to interface to ITS Cabinet or TS2 Type 1 Cabinet. Optional interface modules defined in this standard include:

- Serial to parallel interface module for connection to NEMA TS1 or TS2 type 2 cabinet
- Serial to parallel interface module for connection to Model 332 cabinet

2.2.5 Operating System & Board Support Package Requirements

The ATC shall use a Linux operating system (O/S) and shall include standard POSIX libraries for application support including real-time extensions of POSIX 1003.1b. To facilitate application level access to the ATC hardware, a Board Support Package (BSP) shall be provided for access to hardware-specific drivers.

After boot-up the ATC Linux O/S shall make available to applications, access to the low level drivers (block, character and network) provided by the kernel (subject to current open source requirements) or through kernel modules.

The BSP supplied by a manufacturer shall include the following components:

- 1) A Linux compatible kernel that shall be configured to include, at minimum, the features specified in Annex A.

Advanced Transportation Controller (ATC) Standard

INTRODUCTION

1
2
3
4
5

2) Drivers that support all functionality defined by sections 5.3, On-Board Resources, and 5.4.3, Serial Interface Ports of this document, and be capable of operating in an interrupt driven environment where appropriate. Drivers for the following engine board hardware are required:

Function	Character	Block	Network	Interrupt
/dev/sp1 Asynchronous Port	X			X
/dev/sp1s Synchronous Port	X			X
/dev/sp2 Asynchronous Port	X			X
/dev/sp2s Synchronous Port	X			X
/dev/sp3 Asynchronous Port	X			X
/dev/sp3s Synchronous Port	X			X
/dev/sp4 Asynchronous Port (Note 1)	X			X
/dev/sp5 Asynchronous Port	X			X
/dev/sp5s Synchronous Port	X			X
/dev/sp6 Asynchronous Port	X			X
/dev/sp8 Asynchronous Port	X			X
/dev/sp8s Synchronous Port	X			X
Ethernet 1			X	X
Ethernet 2			X	X
USB		X		X
SPI	X			X
CPU Reset	X			
CPU Active LED	X			
Power Down	X			X
RTC	X			
Datakey Present	X			X
Flash File System		X		X
SRAM File System		X		

6
7
8
9
10
11
12
13
14
15
16
17
18
19
20
21
22
23
24

Notes:

1. A Linux Console shall be provided on /dev/tty4 (/dev/console) at boot-up. All terminal outputs during boot time shall be made to that interface. All inputs are made via a terminal program to that interface. This interface is the default stdin / stdout of Linux. The communication parameters are initially 38400 baud, n, 8, 1. The same communication parameters shall be used by the boot-loader in order to ensure a continuous output to the serial terminal / console. After booting and all applications are loaded, /dev/tty4 shall be available to applications as /dev/sp4 unless the single-user mode Linux feature has been invoked via Ctrl-C during the boot process before control is passed to any application programs.

See Annex B for BSP-specified driver interface details.

3) Utility applications, modules, libraries, and supporting data which include but are not limited to the following:

Package	Version *	Programs	Remarks
Busybox	1.00p8	[, addgroup, adduser,	UNIX shell and commands

Advanced Transportation Controller (ATC) Standard

INTRODUCTION

		adjtimex, ar, ash, basename, busybox, cat, chgrp, chmod, chown, chroot, clear, cmp, cp, crond, crontab, cut, date, dd, delgroup, deluser, df, dirname, dmesg, dos2unix, du, echo, egrep, env, expr, false, fgrep, find, freeramdisk, getty, grep, gunzip, gzip, halt, head, hexdump, hostid, hostname, hwclock, id, ifconfig, ifdown, ifup, inetd, init, insmod, install, kill, killall, klogd, last, ln, logger, login, logname, logread, ls, lsm, makedevs, md5sum, msg, mkdir, mkfifo, mknod, mktemp, modprobe, more, mount, mv, netstat, nslookup, passwd, patch, pidof, ping, pivot_root, printf, ps, pwd, rdate, reboot, renice, reset, rm, rmdir, rmm, route, run-parts, rx, sed, sh, sleep, sort, start-stop-daemon, stty, su, sulogin, sync, sysctl, syslogd, tail, tar, tee, telnet, telnetd, test, time, top, touch, tr, true, tty, umount, uname, uniq, unix2dos, unzip, uptime, usleep, vi, wc, which, who, whoami, xargs, yes, zcat	collection http://www.busybox.net/
UclibC	0.9.27	ld.so, libc, libcrypt.so, libdl.so, libm.so, libnsl.so, libnss_dns.so, libnss_files.so, libpthread.so, libresolv.so, libutil.so	Uclibc Equivalent http://www.uclibc.org/downloads

* Or higher

1
2

2.3 References

2.3.1 Normative References

This standard assumes and is consistent with known versions of ITS cabinet (http://www.ite.org/standards/atc/ITS_Cabinet.pdf) standard.

ATC Standard for the type ATC 2070 Controller

http://www.ite.org/standards/atc/ATC_2070Standard.pdf

10

1
2
3 NEMA TS2-2003 Traffic Controller Assemblies with NTCIP Requirements

4 <http://www.nema.org/stds/ts2.cfm>

5
6 USB Specifications

7
8 **Universal Serial Bus Specification.** Revision 1.1, September 23, 1998.
9 Copyright © 1998, Compaq Computer Corporation, Intel Corporation, Microsoft
10 Corporation, NEC Corporation. All Rights Reserved.

11
12 <http://www.usb.org/developers/docs/usbspec.zip>

13
14 **USB Mass Storage Overview 1.2**

15
16 http://www.usb.org/developers/devclass_docs/usb_msc_overview_1.2.pdf

17
18 **USB Mass Storage Bulk Only 1.0**

19
20 http://www.usb.org/developers/devclass_docs/usbmassbulk_10.pdf

21
22 **USB Mass Storage Control/Bulk/Interrupt (CBI) Specification 1.1**

23
24 http://www.usb.org/developers/devclass_docs/usb_msc_cbi_1.1.pdf

25
26 **USB Mass Storage UFI Command Specification 1.0**

27
28 http://www.usb.org/developers/devclass_docs/usbmass-ufi10.pdf

29
30 **Guidance:** *If the links listed above are no longer valid, it is recommended*
31 *that the user reference the [www.USB.ORG](http://www.usb.org) web site and the*
32 *http://www.usb.org/developers/devclass_docs for a listing of the most*
33 *recent documents which are relevant to the application of USB to the ATC.*

34
35
36 Ethernet 802.3 Specifications

37
38 **IEEE 802.3-2002 Specification**

39
40 <http://standards.ieee.org/getieee802/download/802.3-2002.pdf>